



Centramax™ Centrifuge and Centrapac™ System

Water Technologies

SIEMENS

Centramax™ Centrifuge Delivers Maximum Performance



Total Process Control

The Centramax™ centrifuge design is the result of a combined effort between engineers and operators to provide the most user-friendly, cost-effective, high performance centrifuge available today. Total process control, combined with precision engineering and manufacturing, result in maximum cake solids and solids capture and minimum energy and polymer consumption.

The Centramax™ centrifuge employs the latest in control design technology to simplify system operation and provide total process control, including:

- Operator Interface Terminal (OIT) for system monitoring and touch screen control.
- PLC-based controller to operate entire dewatering system.
- One button system start-up and clean-in-place shut down.
- Torque-based control that constantly monitors and adjusts scroll differential for maximum performance and highest cake solids.
- Modem for remote Siemens support, diagnostics, and program updates.
- Integrated scroll drive control system.



The Centramax™ centrifuge control panel provides total process control through a concise, easy-to-operate touch screen.



Precision Engineering and Manufacturing

Each Centramax™ centrifuge is computer designed and modeled before any manufacturing occurs. Our state-of-the-art manufacturing facility then uses computer aided machines and experienced craftsmen to produce components with precise tolerances. All rotating equipment is balanced and trimmed at actual operating speed before final assembly and testing of the complete system.

- The bowl is manufactured to high tolerances and computer balanced to allow operation at greater than 3,000 G's.
- Independent bowl and scroll drives are provided for minimal energy consumption and maximum control.
- Variable frequency main drive provides low energy starting and optimized operating speeds.
- Closed body scroll design minimizes turbulence and provides a high solids transfer rate.

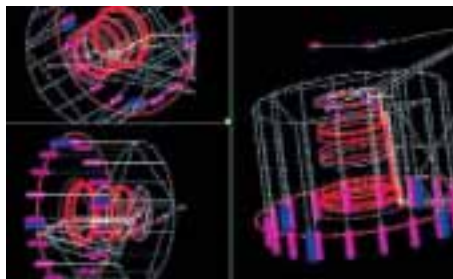

ISO 9001:2000 QMS

The quality management system governing the manufacture of the Centramax™ centrifuge is ISO 9001:2000 certified.

CWB Certification

The Canadian Welding Bureau acknowledges that Siemens Water Technologies is certified to CSA Standard W47.1.

Critical Features Translate into Superior Performance

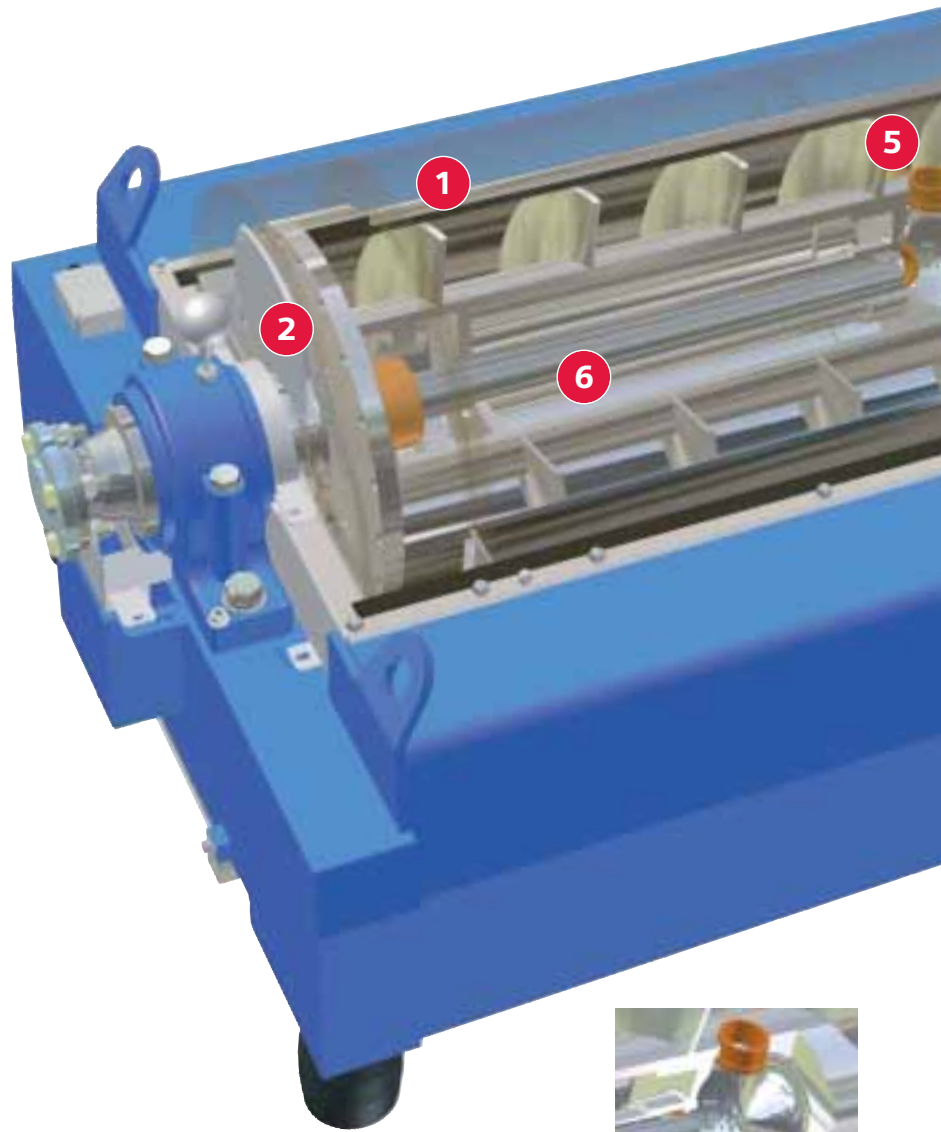

1. Bowl

- Centrifugally cast duplex stainless steel construction for corrosion resistance and low deflection.
- Simplified two-piece construction to reduce vibration.
- Easily serviced without removing the main drive motor.
- Computer balanced to allow operation at greater than 3,000 G's.

2. Centrate Discharge Weirs

- Easily adjustable to optimize pond depth.
- Calibrated weir plates for easy setup and adjustment.

3. Scroll

- Closed body design to minimize turbulence and provide a high solids transfer rate.
- Sintered tungsten carbide abrasion protection package.
- Constant flight gradient to minimize turbulence and improve performance.
- Computer balanced to allow operation at greater than 3,000 G's.
- Continuously welded resulting in a very robust design.





4. Feed Compartment

- Designed to provide additional retention time for floc formation.
- Bell shape provides gentle transition to minimize floc destruction.

5. Feed and Discharge Ports

- Solid sintered tungsten carbide construction for long life.
- Easily replaceable.

6. Feed Tube

- Tapered construction to eliminate harmonic resonance.
- Oversized inner diameter to allow high flow rates with low back pressure.
- Adjustable internal polymer tube for optimal injection point setting.

7. Main Drive

- Side mounted motor to allow for simplified bowl removal.
- Variable Frequency Drive (VFD) controller for operation at optimum speed.

8. Bearings

- 100,000 hour L-10 bearings assures long service life.
- Grease lubrication system for simplified maintenance (660 mm bowl diameter and smaller).
- Non-proprietary bearings for cost-effective replacement.

9. Base

- Solid steel end plates for reduced vibration.
- Rugged welded steel box frame minimizes vibration and ensures stability.

10. Casing and Cover

- Stainless steel for durability and long life.
- Inspection plates for easy adjustment of critical components.



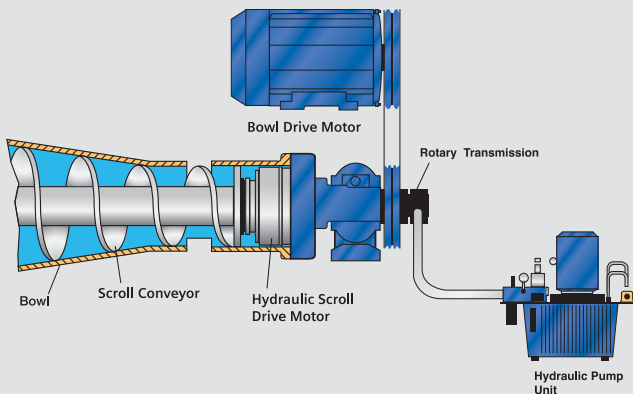

Hydraulic Scroll Drive

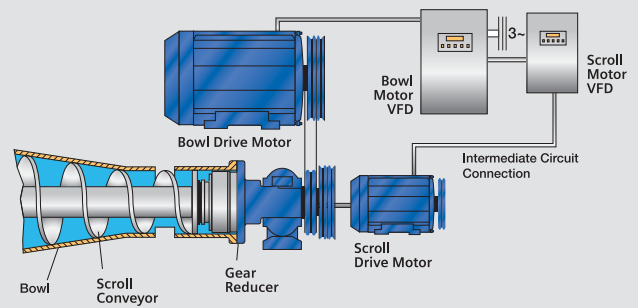

Mechanical Scroll Drive

The Scroll Drive System: The Heart of the Centrifuge

The scroll drive controls the differential speed between the scroll and the bowl and is critical to centrifuge performance. This differential dictates the residence time of the solids in the centrifuge, which has a direct correlation to cake solids concentration and capture efficiency. Obtaining and sustaining a consistent cake solids and capture efficiency requires a very sensitive scroll drive that responds rapidly to changes in sludge characteristics by making smooth, subtle changes in the scroll speed. Two highly effective scroll drive systems are available for the Centramax™ centrifuge.

Siemens offers two distinct scroll drive systems to meet the needs of any dewatering application.

Hydraulic Scroll Drive

The hydraulic scroll drive system consists of an electric main drive motor and hydraulic scroll drive motor, which turn the bowl and scroll independently. The fully independent hydraulic scroll drive has the ability to generate and sustain an extremely high degree of torque. This high torque capability, combined with a very rapid response time, allows the centrifuge to consistently produce the highest cake solids.

Mechanical Scroll Drive

The mechanical scroll drive system consists of an electric main drive motor and an electric scroll drive motor, both controlled by independent variable frequency drives (VFD). This drive package uses a sophisticated energy recovery system that minimizes overall power requirements and operating costs.

Centramax™ Centrifuge Sizing Chart

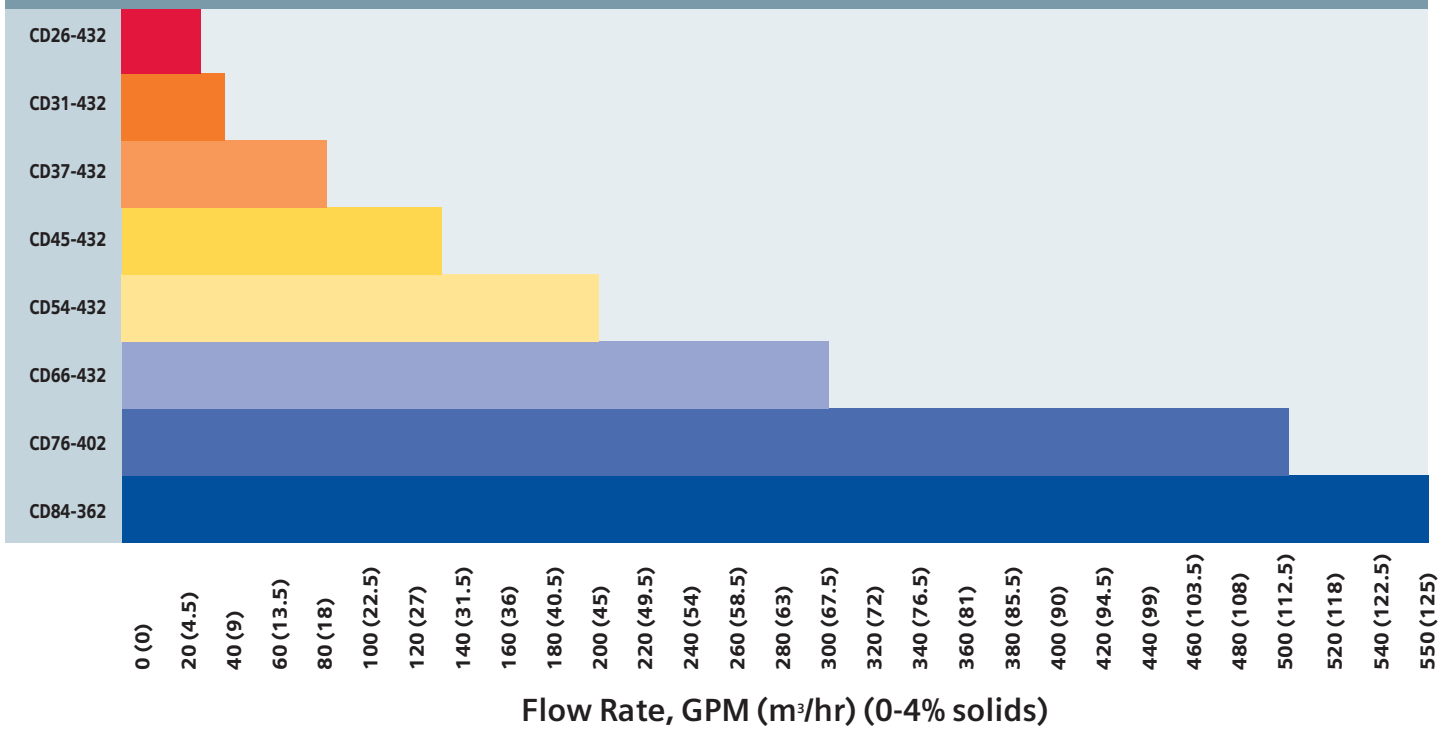

Model No.	CD26-432	CD31-432	CD37-432	CD45-432	CD54-432	CD66-432	CD76-402	CD84-362
Bowl Diameter, in. (mm)	10 (260)	12 (310)	15 (370)	18 (450)	21 (540)	26 (660)	30 (760)	34 (840)
Overall Length, in. (mm)	84 (2135)	93 (2365)	110 (2795)	126 (3200)	144 (3660)	175 (4445)	234 (5945)	201 (5105)
Overall Width, in. (mm)	44 (1120)	44 (1120)	53 (1350)	58 (1475)	64 (1625)	77 (1960)	107 (2720)	119 (3025)
Overall Height, in. (mm)	32 (815)	35 (890)	42 (1070)	42 (1070)	44 (1120)	48 (1220)	51 (1300)	57 (1450)
Weight—Dry, lbs. (kg)	2930 (1330)	3310 (1500)	5510 (2500)	7050 (3200)	9700 (4400)	16090 (7300)	28100 (12750)	28110 (12750)

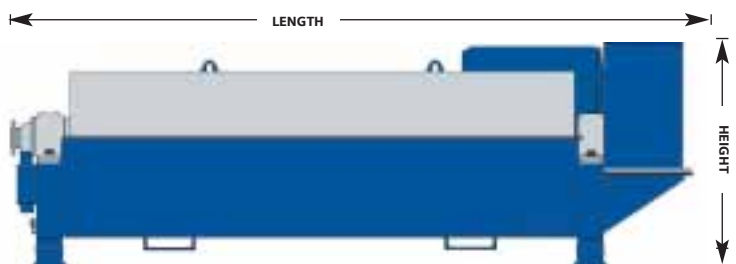
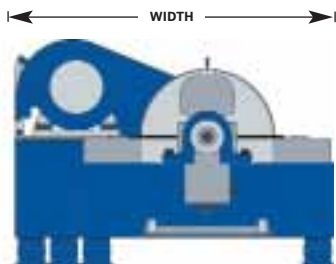

Flow rates shown are for information only. Actual capacity may vary dependent upon feed characteristics.

Centrapac™ Centrifuge Dewatering System



Small Footprint, Large Output

The Centrapac™ system is a complete, centrifuge-based dewatering system that offers a “plug and play” solution to sludge dewatering. Configured to meet your specific requirements, this system brings the state-of-the-art Centramax™ centrifuge and the best ancillary equipment together in one high performance package.

Installation is simple and efficient. The Centrapac™ system is completely prefabricated and pre-engineered and includes everything but power. Simply set the system in place, connect the utilities and the system is ready to go.

All settings are accessible from the large color touch screen. Operation is easy and highly automated with a simple, “one button” startup and shutdown feature.

The Centrapac™ system automatically adjusts to variations in the feed solids to provide highest cake solids, maximum recovery and minimum polymer consumption. It is so easy to operate that it virtually runs itself.

Centrapac™ System

The Centrapac™ centrifuge dewatering system is a complete skid mounted package that includes the Centramax™ centrifuge, plus:

- **Sludge Feed Pump** — The sludge feed pump is matched to the application and is controlled via a Variable Frequency Drive through the Programmable Logic Controller.
- **Siemens Polyblend® Unit** — The Polyblend® unit will meter, mix, and deliver polymer at the optimum dosage to obtain maximum system performance and efficiency.



Full Range of Capacities

Model No.	CP26-432	CP31-432	CP37-432	CP45-432	CP54-432
Bowl Diameter, in.	10	12	15	18	21
Bowl Diameter, mm	260	310	370	450	540
Installed Power, HP	25 (19)	35 (26)	50-55 (37-41)	75-85 (56-63)	130-140 (97-104)
Electrical Supply	480V/3/60Hz	480V/3/60Hz	480V/3/60Hz	480V/3/60Hz	480V/3/60Hz
Length, in.	120	112	120	120	163
Length, mm	3050	2845	3050	3050	4140
Width, in.	64	64	72	72	72
Width, mm	1625	1625	1830	1830	1830
Height, in.	83	90	100	100	99
Height, mm	2100	2290	2540	2540	2515
Overall Weight, lbs.	7,900	9,300	13,500	16,000	19,000
Overall Weight, kg	3585	4200	6125	7260	8620

All dimensions are approximate and should only be used for reference. For more precise sizing, please contact Siemens or its authorized representative. Width dimension does not include the conveyor.

- **Control Panel** — The NEMA 4 enclosure features an Operator Interface Terminal (OIT) that provides control of all functions, and displays parameters such as sludge and polymer flow rates, bowl speed, differential speed, etc.

- **Siemens Screw Conveyor** — The Screw Conveyor provides reliable conveyance of dewatered cake from the centrifuge to a bin or truck. The conveyor is specially designed to route the liquid encountered during startup and shutdown to a drain at the base of the trough.

Centrapac™ System Features

- Completely assembled, piped and wired for minimal installation time and cost.
- Single source responsibility for all components.
- Configured to meet your specific requirements for automation, throughput, polymer, and conveyance.

- “Industry best” components for outstanding performance at lowest total cost.
- Flexible — accommodates change in process volumes, variation in feed solids, and sludge types.
- Heavy-duty skid and support stand.

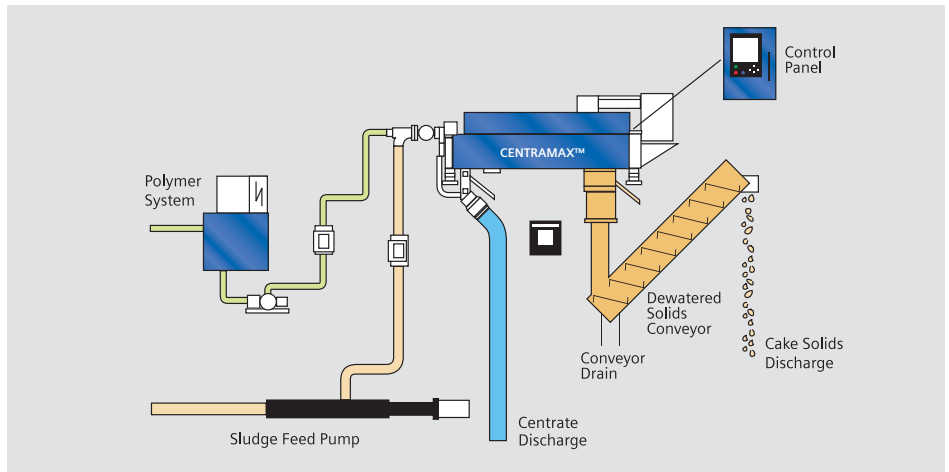



Our large parts distribution center ensures that many parts are available for same day shipment.

An Ongoing Investment in Your Satisfaction

Preventative and Predictive Maintenance Services We can customize a cost-effective program for your specific equipment, application, and environment that translates into lower maintenance cost and years of worry-free operation.

Parts Repair Service Our professional service staff can quickly and reliably answer your technical questions and troubleshoot your specific requirements, schedule parts shipments, and arrange for an on-site service call.

Refurbishment Services Through our Regain Program, we can rebuild, refurbish or optimize your equipment to regain efficiency, throughput, and productivity and to lower your costs. We can provide a partial or complete rehabilitation to warranted like-new condition, at your site or ours.

For more information on our Aftermarket Services, call 800.245.3006.

Aftermarket Services

- Factory-based customer service support.
- Expert technical consulting.
- Same-day shipment on many service and spare parts.
- Worldwide repair and preventative maintenance services.
- Emergency support services.
- Equipment retrofits, upgrades, and refurbishment.
- Training.
- Testing, evaluative and customized services.



The Siemens mobile testing unit provides on-site analysis to ensure an accurate assessment of performance and operating costs.

Laboratory Services — an Informed Decision is the Best Decision

Siemens maintains a fully-staffed, state-of-the-art laboratory for determining the most effective liquid/solids separation techniques for your specific application. Capabilities range from feasibility testing of your materials to providing portable pilot units for on-site testing. This customer-focused resource produces tangible results: we can determine the most effective feed pressures, fill times, filter media and sludge conditioning. In addition to ensuring a better informed equipment purchase, this valuable service is also available to help you maintain maximum performance of your investment.

Complete Dewatering Solution

Through years of experience across thousands of installations, Siemens Water Technologies understands what

equipment and process technologies are required to produce drier cake with minimum chemical usage, manpower and energy requirements. You can rely on Siemens for full project management and performance guarantees. Whether your dewatering requirements are organic or inorganic, wastewater or process, industrial or municipal, our team of experts can help you achieve your goals for efficiency, cost-reductions, compliance, or reuse.



Centramax™ systems are hard at work the world over delivering dry cake at a lower cost.



We offer complete material handling solutions to fit your plant layout and process needs.

Centramax, Centrapac and Polyblend are trademarks of Siemens, its subsidiaries or affiliates.

NEMA is a trademark of the National Electrical Manufacturers Association.

Product is covered by U.S. patent no. 5674384, Canadian patent no. 2235404, German patent no. 69617727.7, and United Kingdom patent no. 0862489.

The information provided in this brochure contains merely general descriptions or characteristics of performance which in actual case of use do not always apply as described or which may change as a result of further development of the products. An obligation to provide the respective characteristics shall only exist if expressly agreed in the terms of contract.

+1. 616.772.9011
dewatering.water@siemens.com

E10001-WTEPS-A8-V2-4A00
DispoNo.21616 K-No.3936

EP-CENT-1UE-BR-0408
Subject to change without prior notice.

© 2008 Siemens Water Technologies Corp.